

24 October 2000

NEW CELICA 190 - THE WORLD'S MOST HIGH TECH ENGINE FOR UNDER £21,000

What distinguishes the new Celica 190 from its stable mate is not immediately obvious for it lives under the bonnet, or under the driver's right foot to be exact. Still a 1.8-litre, four cylinder engine - although technically it has an extra two cc - the Celica 190 is one of a very rare breed of cars that has over 100hp per litre.

Unlike the smug folk in the Honda ads who boast about their Accord having seventy-something horse power per litre, the Celica 190, with 106.7hp/litre is up there with the likes of the McLaren F1 (103.3hp/litre), the BMW M3 (106hp/litre) and the Ferrari 360 Modena (111.5hp/litre).

With 189hp at 7,800rpm and 184Nm at 6,800rpm the Celica 190 is capable of 0-62mph in 7.4 seconds (the standard Celica is 8.7 seconds) and a top speed of 140mph (127mph). But it is not just fast, it is frugal too. The combined fuel consumption figure is 33.6mpg and CO₂ emissions just 200g/km.

On sale now, the new Celica 190 costs £20,495 OTR.

More Power

The new Celica, the seventh generation of this successful sports coupe, was introduced in late 1999 and was immediately praised for its light weight, responsive handling and sharp styling. If there was one flaw it was the low end punch. The new Celica 190 answers that question with an extra 50hp thanks to one of the most technically advanced road car engines ever.

As well as four valves per cylinder and variable valve timing like all other new Toyotas, the Celica 190 also has variable valve lift. In layman's terms that means parts of the engine can physically change shape to give high power as well as smooth economy throughout the rev range.

Six In Hand

With an 8,200rpm red line the Celica 190 driver gets to play racer with the engine thanks to the six-speed manual gearbox. Loads of fun is to be had as the gearing has been selected to allow the sporting driver to keep the engine well within its wide power band.

Red Label

Externally identical to the standard 140hp Celica, only the rear badges will give the game away to car-spotting little boys or following drivers. Uniquely on the Celica 190 the Toyota badge is in red rather than chrome and the VVT-i badge has the numerals "190" added, again in red.

Internally the Celica 190 has standard leather upholstery and climate control air conditioning as standard. The instruments are also changed to reflect the higher rev limit and potentially higher top speed of the new engine.

More Than A Head Lift

The Celica 190 engine has more than a new head with variable valve lift added - as if that wasn't enough. Toyota engineers changed the bore (wider), stroke (shorter) and compression ratio (higher) to produce better low speed torque and higher revs. The valve diameter is also increased to help the engine breathe better.

These changes not only give a two cc increase in capacity, but allied to the variable valve timing and lift retain the low emissions and good fuel economy you would expect from a 1.8-litre engine.

The VVTL-i (Variable Valve Timing with Lift-intelligent) system is based on the standard VVT-i system, which varies the intake valve timing continuously from the low speed to high speed ranges. The VVTL-i also increases the intake/exhaust valve lift when the engine speed is high, in order to increase the output and to achieve better fuel economy.

Outline of VVTL-i

The table below illustrates how VVTL-i operates under a variety of driving conditions:

Operation State	Variable Valve Timing	Operating Cam
Idling		Low
Low to medium speed range with partial load	Optimum control According to	Low
Low to medium speed range with full load	Operation state	Low
High speed range with heavy load		High

Rocker Arm - Description and Structure

A cam changeover mechanism to enable variable valve lift is built into the Celica 190 engine. A needle roller is used on each part that is in contact with a 'low-speed' cam. This is referred to as the low speed roller. The high speed slipper is mounted on the rocker arm and 'floats' within its position. The slipper is fixed by the operating pin during high-speed operation.

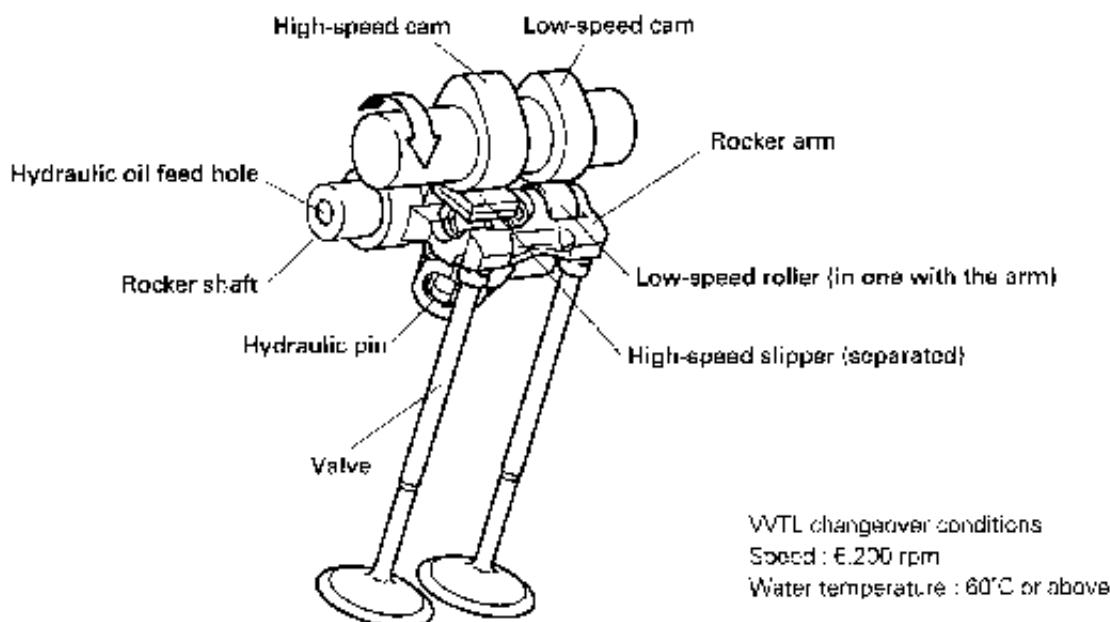

Rocker Arm - Operation

In low to medium speed ranges, the valves are driven by the low-speed cams as the high speed slippers are not fixed - they are in their floating state.

In the high-speed range, the valves are driven by the high-speed cams as the high-speed slippers will be fixed hydraulically by the hydraulic pins.

Low to Medium Speed Range High Speed Range

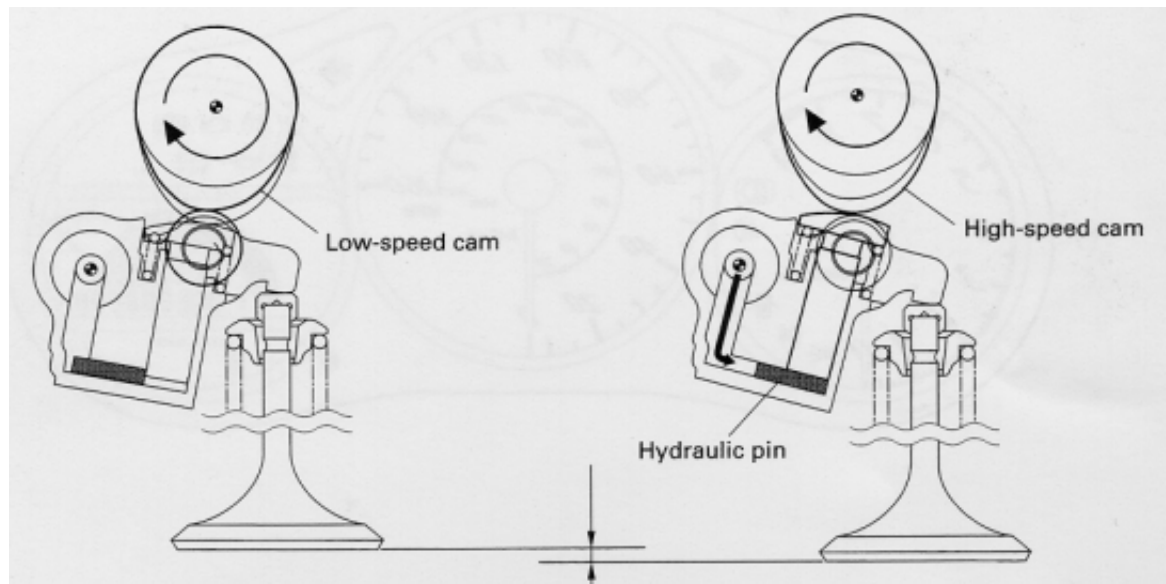

Transmission

A manual transmission with six gears is used in conjunction with the Celica 190 engine. It is similar to the six-speed manual transmission used with the standard Celica engine, but with different gear ratios to best exploit the power and torque characteristics of the engine.

Gear Ratio	Celica	Celica 190
In First	3.166	3.166
In Second	1.904	2.050
In Third	1.310	1.481
In Fourth	1.031	1.166
In Fifth	0.864	0.916
In Sixth	0.725	0.815
In Reverse	3.250	3.250

Standard Specification

The Celica 190 standard specification includes:

- Driver, front passenger and front seat side airbags
- ABS with EBD
- Sony RDS radio/cassette/CD tuner
- Remote central locking with double locking
- Thatcham 1 alarm/immobiliser
- Climate control air conditioning
- Electric tilt/slide sunroof
- Leather front seats
- Aluminium effect pedals

The Sport and Dynamic Option Packs will also be offered on the Celica 190 (Sport = £1,200; Dynamic = £1,900). The 17" alloy wheel design on Sport/Dynamic Pack fitted to Celica 190 will be a different design to the 17" alloy wheels that form part of the Sport/Dynamic Pack fitted to the standard (140bhp) Celica.

Pricing

	Basic £	VAT £	Retail £	OTR £
Celica 190	£16,863.83	£2,951.17	£19,815.00	£20,495.00
Celica 190 with optional Sport Pack	£17,885.11	£3,129.89	£21,015.00	£21,695.00
Celica 190 with optional Dynamic Pack	£18,480.85	£3,234.15	£21,715.00	£22,395.00
Metallic Paint	£234.04	£40.96	£275.00	N/A

Correct as @ October 2000

On the road pricing includes delivery (£475), number plate allowance (£25), 12 months Vehicle Excise Duty (£155) and First Registration Fee (£25).

All prices shown are recommended retail applicable to vehicles sold for permanent use in the UK.

FULL EQUIPMENT LIST

SAFETY	Celica	Celica 190
Driver & front passenger airbags with hybrid inflators	✓	✓
Driver & front passenger seat mounted side airbags	✓	✓
Electronically controlled ABS with electronic brake distribution logic (EBD)	✓	✓
Electronic sensing front seatbelt pretensioners with force limiters	✓	✓
Four 3-point seat-belts with ELR	✓	✓
Seat integrated front seat belt anchorage and support	✓	✓
Rear seatbelts with ALR and ELR	✓	✓
High mounted stop lamp (HMSL)	✓	✓
De-coupling brake pedal mechanism	✓	✓
Anti-trap on automatic up driver's window	✓	✓
Anti-trap on automatic close sunroof	N/A	✓
Energy absorbing, deformable and retracting steering column	✓	✓
Pipe side impact beams in side doors	✓	✓
Front bumper reinforcement	✓	✓
Outside temperature display	N/A	✓
Energy absorbing crumple zones front and rear	✓	✓
Front, side and head impact absorbing structure	✓	✓
Anti-submarining seat design	✓	✓
Auto cancel rear fog lamps	✓	✓
INSTRUMENTS & CONTROLS		
Tachometer	✓	✓

Water temperature gauge	√	√
Outside temperature display	N/A	√
Twin speed & variable intermittent front wash wiper control with mist function	√	√
COMFORT & CONVENIENCE		
Power Assisted Steering (PAS)	√	√
Electric front windows	√	√
Driver's window electric one touch up and down with safety anti-trap	√	√
Electric tilt/ slide sunroof with shade, one touch open/close anti-trap	N/A	√
Central locking with remote control and double locking	√	√
Electric & heated exterior mirrors	√	√
Stepless tilt adjustable steering column	√	√
Remote courtesy light operation with delay	√	√
Remote fuel release	√	√
Driver and Passenger vanity mirrors with covers	√	√
Illuminated ashtray and Cigar lighter	√	√
Rear coat hooks	√	√
Heated rear window	√	√
Luggage load hooks in boot	√	√
Rear parcel shelf	√	√
Driver's footrest	√	√
Leather steering wheel cover and gear shift knob	√	√
Fully trimmed boot with light	√	√
INSTRUMENTS & CONTROLS		
Intermittent & continual sweep rear wash wiper control	√	√
Fuel gauge with low fuel warning light	√	√
Digital clock	√	√
Electric headlamp levelling	√	√
Instrument light dimmer and fuel cap location indicator	√	√
Digital odometer/trip meter	√	√
Engine management warning and fog lamp indicator lights	√	√
AUDIO		
Sony radio cassette CD player	√	√
Roof aerial	√	√
VENTILATION		
Manual air-conditioning	√	See next item
Digital climate control air-conditioning	N/A	√
Electric tilt/slide sunroof	N/A	√
Air-recirculation	√	√
SECURITY		

SECURITY		
Remote alarm with perimeter and microwave interior protection	✓	✓
Transponder Key engine Immobiliser	✓	✓
Steering column lock	✓	✓
Lockable glove box	✓	✓
Double locking	✓	✓
SEATING, UPHOLSTERY & TRIM		
Driver & passenger seat recline & slide adjustment	✓	✓
Driver seat cushion height adjustment	✓	✓
50/50 split rear seat back	✓	✓
Cloth front seat trim and door inserts	✓	N/A
Dark grey cloth rear seats	✓	N/A
Leather front seats and door inserts	N/A	✓
Dark grey leather-look vinyl rear seats	N/A	✓
Aluminium effect pedals	dealer option	✓
STORAGE		
Large capacity glove box	✓	✓
Centre console storage box	✓	✓
Centre tunnel storage with CD capacity	✓	✓
Front seat back pocket (behind front passenger seat only)	✓	✓
Front and rear cup holders	✓	✓
Front door storage bins	✓	✓
EXTERIOR & BODY		
Body coloured mirrors and door handles	✓	✓
Body coloured bumpers	✓	✓
Front fog lamps	✓	✓
16" alloy wheels with locking wheel nuts	✓	✓
Sport Pack comprising 17" alloy wheels and rear spoiler*	option	option
Dynamic Pack comprising 17" alloy wheels, rear spoiler and side skirts*	option	option
Metallic paint	option	option

* The 17" alloy wheel design on Sport/Dynamic Pack fitted to Celica 190 will be a different design to the 17" alloy wheel that forms part of the Sport/Dynamic Pack fitted to the standard (140bhp) Celica.

CELICA TECHNICAL SPECIFICATIONS - HIGHLIGHTS

WEIGHT (kg)	Celica	Celica 190
Kerb Weight	1185	1215
Gross vehicle weight	1595	1595

PERFORMANCE	Celica	Celica 190
Max speed (mph)	127	140
0-62mph (sec)	8.7	7.4
FUEL CONSUMPTION	Celica	Celica 190
EMISSIONS		
Urban cycle (mpg)	27.4	24.6
Extra Urban (mpg)	45.6	42.8
Combined (mpg)	36.7	33.6
CO ₂ Emissions (g/km)	185	200
ENGINE	Celica	Celica 190
Type	1ZZ-FE	2ZZ-GE
Capacity cc	1794	1796
Bore & Stroke mm	79 x 91.5	82 x 85
Compression ratio	10.0 : 1	11.5 : 1
Max output (bhp/rpm)	140@6,400	189@7,800
Max torque (Nm/rpm)	173@4,200	184@6,800
GEAR RATIOS	Celica	Celica 190
In First	3.166	3.166
In Second	1.904	2.050
In Third	1.310	1.481
In Fourth	1.031	1.166
In Fifth	0.864	0.916
In Sixth	0.725	0.815
In Reverse	3.250	3.250

Ref:1024N



New Celica 190 - The world's most high tech engine for under £21,000

limited 10,000

[View / Open](#)

[Download / Add to basket](#)

[VIEW
HIGH RES](#)

[VIEW
MEDIUM RES](#)

[DOWNLOAD
HIGH RES](#)

[DOWNLOAD
MEDIUM RES](#)